



## Renewable Energy

### Renewable Energy

All renewable energy sources derive from the Sun. The Sun provides the energy that drives our weather systems and water cycle. It is the prime source of all energy on Earth and it is essential for all forms of life on Earth. Renewable energy is the exploitation of energy from naturally occurring phenomena, such as ocean tides and wind. Renewable energy quickly replaces itself and is generally available as a never-ending source.

### Sun

The Sun has an immense output of energy. Energy from the Sun is called solar energy and is emitted with many ranges of wavelengths. Only a small part of this energy is intercepted by the earth, reaching us, e.g., in the form of visible light. The amount of power in the Sun's rays that reach Earth is measured in watts per square meter.

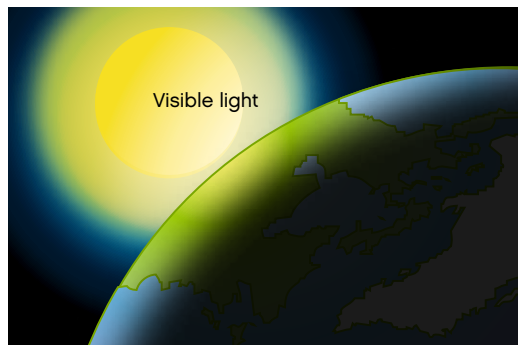

### Wind

The Sun's heat is absorbed quicker by land than by the ocean. Warm air over land is less dense than the cool air over the ocean, so it rises and is replaced by the cooler air over the ocean. This movement and changes in temperature is responsible for the movement of air in the atmosphere.

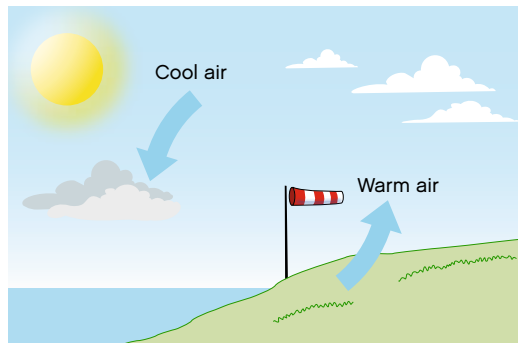

### Water

The Sun's heat warms the water in the oceans causing it to evaporate as water vapour into the air. This water vapour condenses into clouds and falls back to the surface as precipitation, e.g., rain and snow. The water flows through streams and rivers back into the oceans, where it can evaporate and begin the cycle over again.

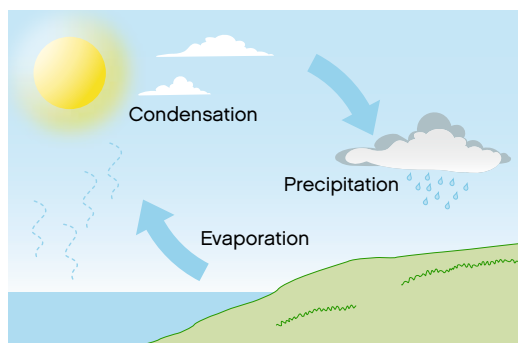

## Solar Energy



Solar energy can be captured by, e.g., solar cells. Many solar cells assembled together are called solar panels. Solar panels are designed to capture the sun's energy and convert it to more exploitable forms, such as heat or electricity. Technologies linked to solar energy are:

- **Passive solar energy**, in which the energy in sunlight is used for light and heat. In passive solar building design the Sun's energy contribution is fully optimised.
- **Active solar water heating systems**, in which the Sun's heat energy is transferred to special fluids held in solar collectors. This fluid is pumped through pipes in water tanks and the heat energy transferred to the water.
- **Photovoltaics**, in which the energy in visible light from the Sun is converted directly into an electric current by means of solar cells. Using the photoelectric effect, 'loose' electrons in the upper layer of the solar cell are caused to move, thus creating an electric current that can be used to operate an electrical device.

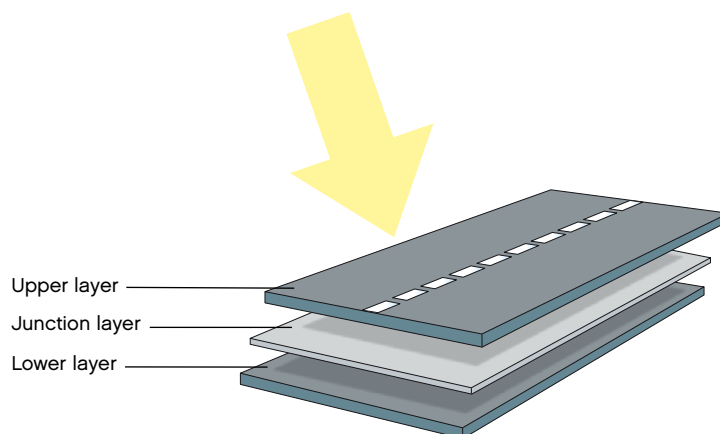

## Wind Energy



Wind energy can be captured by, e.g., wind turbines. Wind turbines are designed to capture the wind's energy and convert it into a more useful form, such as electricity. Technologies linked to wind energy are:

- **Wind turbines with a vertical axis** have a rotating axis and blades in a vertical position. They work equally effective irrespective of wind direction.
- **Wind turbines with a horizontal axis** have a rotating axis and blades in a horizontal position. They must be faced with respect to wind direction and are the most common type of wind turbine to be found, both onshore and offshore.
- **Wind turbines, whether onshore or offshore**, can generate the same amount of power. The key issue of efficiency lies in where the turbines are placed. Offshore wind turbines are often considered more reliable due to the wide open spaces at sea where wind is able to gain energy. Onshore and offshore wind turbines have the same basic parts: tall towers, large turbine blades, axles, gears and a generator.

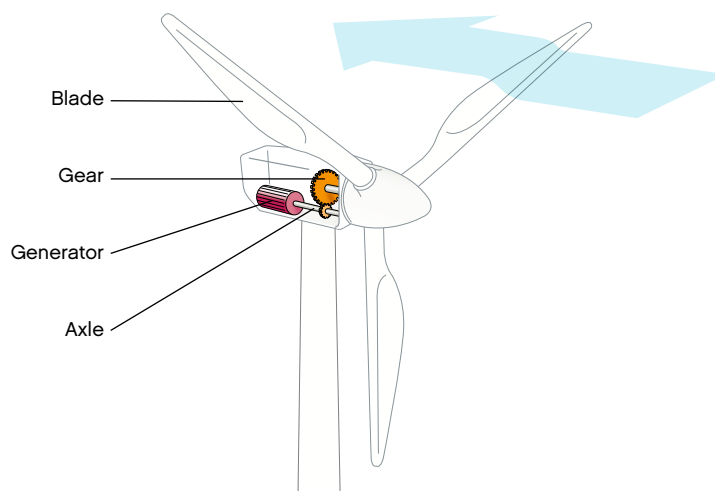

## Hydro Energy



Hydro energy can be captured by, e.g., hydro turbines. Hydro turbines are designed to capture the energy in moving water and convert it into a more useful form, such as electricity. Technologies linked to hydro energy are:

- **Wave energy**, in which the energy in the wave motion of the ocean is captured and used to generate electricity. The waves can be funnelled into a channel or basin to increase their size and hence the available energy. This energy is then used to spin turbines, which in turn drive a generator that generates electricity.
- **Tidal energy**, in which the energy in the tidal current is captured and used to generate electricity. A tidal barrage is built across an estuary or inlet. The barrage has gates in it that allow the water to pass through. When the tide has stopped flowing in the gates are closed, creating a large 'head' of water. When the tide flows back, the receding water is channelled through turbines in the gates that generate electricity.
- **Hydroelectric power plants**, in which the energy from water in movement is extracted to generate electricity. Most large-scale hydro power plants control the water in reservoirs or dams and channel the water through pipes, also called penstocks, causing the water to flow faster and driving turbines to generate electricity.

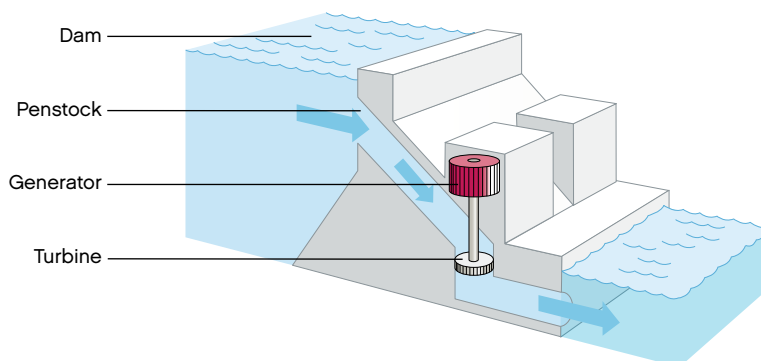

## For further discussion in class

The following discussion points are optional, but might help provide a potential consolidation and clarification of the Renewable Energy concept. They provide the opportunity for students to share their impressions on what energy is and to gain an understanding of different developments dealing with renewable energy. Depending on the student's personal experience or observations, answers will vary. It is important that different viewpoints and explanations are valued and used to build up an overall understanding that is moving towards scientific understanding.

- **What is energy?**

*Energy is the capacity or ability to do work. Energy is a vital part of our everyday lives. Energy can be stored to be used later and energy can change from one form to another. Energy cannot be made or destroyed as stated in the Law of Conservation of Energy.*

- **How is the Sun's energy transferred to Earth and how do we depend on this?**

*The Sun is our primary source of energy. When it is transferring radiation energy to the Earth, e.g., as light waves, it causes such phenomena as plant growth, wind, ocean currents, and the water cycle.*

- **How do you define a renewable and a non-renewable energy source?**

*Energy derived from naturally occurring and inexhaustible sources, like solar, wind and hydro, are all renewable energy sources. Energy derived from a finite source, like coal, oil and gas, are non-renewable energy sources.*

- **How many domestic electrical appliances have you been in contact with since you woke up?**

*Electricity is the main source of energy in our homes. Electrical energy can be changed to make light energy, heat energy, and sound energy. Students may have been in contact with an electrical alarm or a mobile phone, some may have turned on a light, a radio or the television, some might also have used an electric kettle or opened a refrigerator.*

- **Do you know any energy-efficient appliances or other ways we can save on energy?**

*Newer electrical appliances will usually have an energy rating; students can check these. Or alternatively, check some of the school's electrical appliances. Replacing incandescent light bulbs with energy saving light bulbs also saves energy. Other ways of saving energy could be by turning off the lights if the Sun is shining in, by turning off the computer or television instead of switching to standby mode and by simply minimizing electrical needs.*

- **Do you know of any examples of how a renewable energy source is being used in your area?**

*It is likely that student's knowledge will vary and might also be conflicting. Here is an interesting opportunity for the class to 'find out the facts' and learn more about the way information can be presented. Information varies according to vested interests. From an activity such as this, the class might draw up a list of the advantages and disadvantages of different renewable energy sources. When listing, they can consider specific social, economic, political and/or environmental interests.*